

# Art. 9825 / 9826 – CURVE

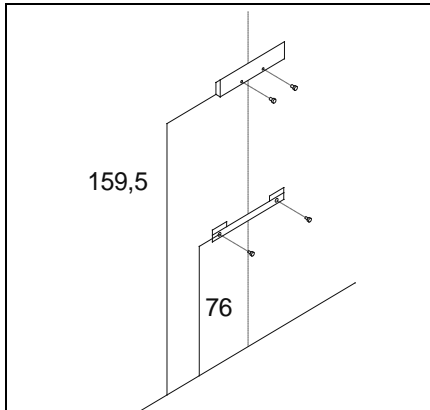

## SCHEMA DI MONTAGGIO

### SCHEMA DE MONTAGE



- FISSARE I GANCI A MURO
- FIXER LES CHROCHETS AU MUR
- FIX THE HOOKS AT THE WALL
- FIJAR LOS GARFOS EN LA PARED

## INSTALLATION INSTRUCTION

### ESQUEMA DE MONTAJE

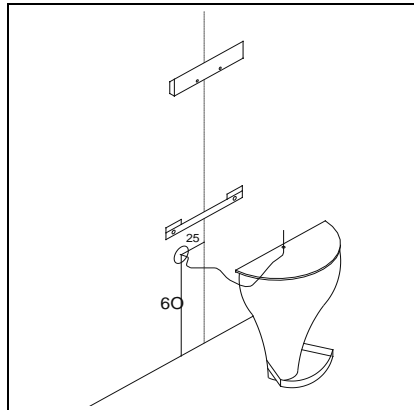

- **NEL CASO DI COLLEGAMENTO ELETTRICO DIETRO LA BASE**, FAR PASSARE IL FILO NEL FORO SUL PIANO; ATT.NE RISPETTARE LA MISURE INDICATE
- **DANS LE CAS DE BRANCHEMENT ELECTRIQUE DERRIERE LA COIFFEUSE** IL EST NECESSAIRE DE FAIRE PASSER LE CABLE DANS LE TROU SUR LE TOP; RESPECTER LES MEASURES
- **IN CASE OF ELECTRICAL CONNECTION BEHIND THE BASE** IT'S NECESSARY TO MAKE THE CABLE PASS THROUGH THE HOLE IN THE TOP; RESPECT THE MEASURES
- **EN CASO DE CONEXION ELECTRICA DETRAS DE LA BASE** ES NECESARIO HACER PASAR EL CABLE DENTRO DEL AGUJERO EN LA ENCIMERA; RESPECTAR LAS MEDIDAS

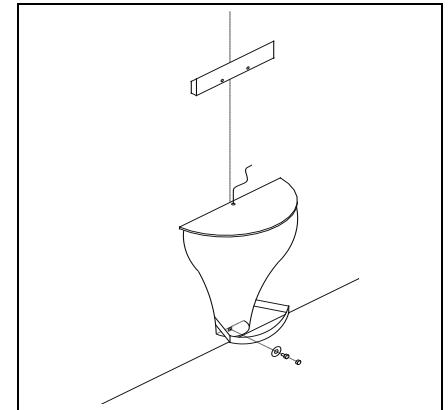

- INCASTRARE LA BASE AL SUPPORTO E FISSARLA IN BASSO COME DA DISEGNO
- ACCROCHER LA COIFFEUSE AU SUPPORT ET LA FIXER EN BAS
- EMBED THE BASE TO THE SUPPORT AND FIX IT IN THE LOWER PART
- ENCAJAR LA BASE AL SUPORTE Y FIJARLA DE BAJO

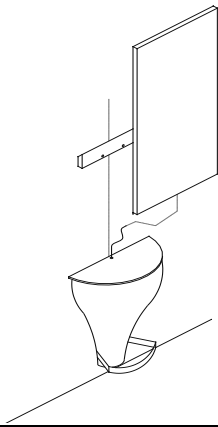

- FARE I COLLEGAMENTI ELETTRICI
- FAIRE LES CONNECTIONS ELETTRIQUES
- MAKE THE ELECTRICAL CONNECTIONS
- HACER LOS COLEGAMENTOS ELECTRICOS

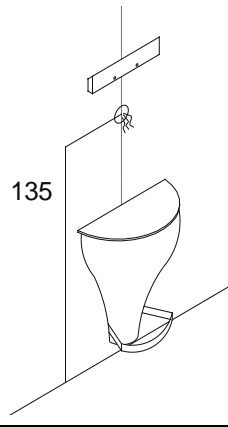

- **NEL CASO DI COLLEGAMENTI ELETTRICI DIETRO LO SPECCHIO.** SALTARE IL PUNTO 2 ED IL PUNTO 4, DOPO IL PUNTO 3, EFFETTUARE I COLLEGAMENTI ELETTRICI ALLA MISURA INDICATA
- **DANS LE CAS DE BRANCHEMENT ELECTRIQUE DERRIERE LE MIROIR** IL NE FAUT PAS CONSIDERER LES POINTS 2 ET 4, APRES LE POINT 3 FAIRE LA CONNECTION ELECTRIQUE EN SUIVANT LES MEASURES INDIQUEES
- **IN CASE OF ELECTRICAL CONNECTION BEHIND THE MIRROR** DON'T FOLLOW THE POINT 2 AND 4, AFTER POINT 3 MAKE THE ELECTRICAL CONNECTION AT THE INDICATED MEASURE
- **EN CASO DE CONEXION ELECTRICA DETRAS EL ESPEJO** NO CONSIDERAR LOS PUNTOS 2 Y 4, DESPUES EL PUNTO 3 HACER LA CONEXION ELECTRICA SEGUN LAS MEDIDAS INDICADAS

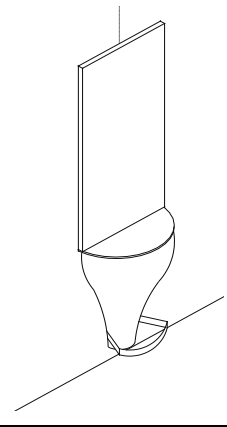

- INCASTRARE LA SPECCHIERA AL GANCIO
- ENCASTRER LA GLACE AUX CHROCHET
- EMBED THE LOOKING GLASS TO THE HOOK
- ENCAJAR EL TOCADOR AL SUPORTE