

Art. 5052 – RETRO' 2.0

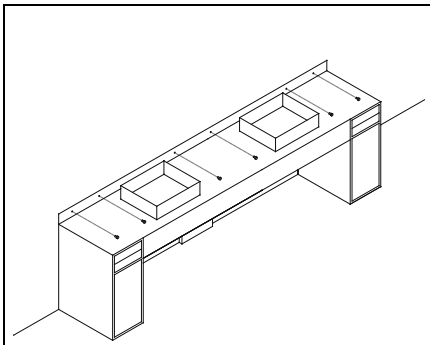

SCHEMA DI MONTAGGIO

SCHEMA DE MONTAGE



- FISSARE LA BASE AL MURO CON 6 VITI
- FIXER LA BASE AU MUR PAR 6 VIS
- FIX THE BASE TO THE WALL WITH 6 SCREWS
- FIJAR LA BASE A LA PARED CON 6 TORNILLOS

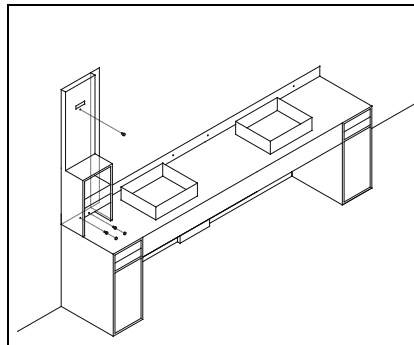

- ACCOSTARE LA COLONNETTA AL BORDO DELLA BASE E FISSARLA AL MURO
- POSITIONNER LA COLONNE AU BORD DU PLAN DE TRAVAIL ET LA FIXER AU MUR
- BRING THE COLUMN TO THE EDGE OF THE BASE AND FIX IT TO THE WALL
- LLEVAR LA COLUMNA AL BORDE DE LA BASE Y FIJARLA A LA PARED

INSTALLATION INSTRUCTION

ESQUEMA DE MONTAJE

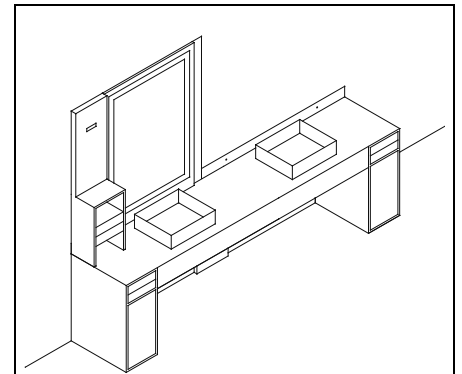

- INCASTRARE LO SPECCHIO ALLA COLONNETTA
- ENCASTRER LE MIROIR A' LA COLONNE
- FIX THE MIRROR TO THE COLUMN
- FIJE EL ESPEJO A LA COLUMNA

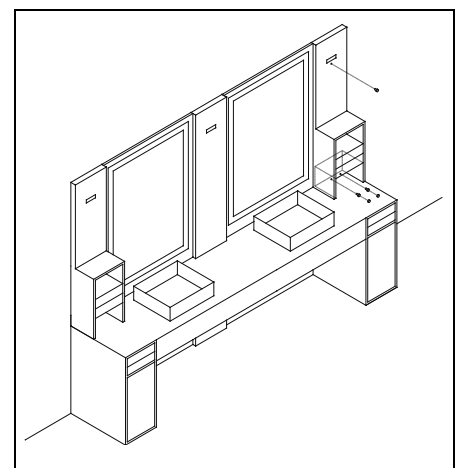
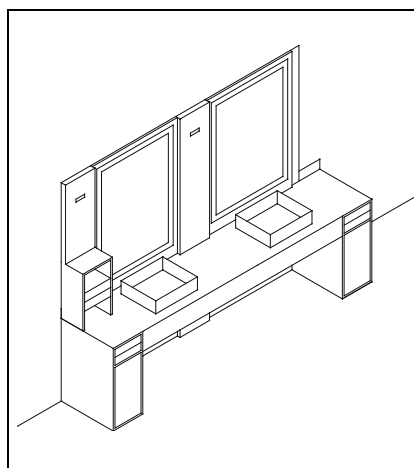
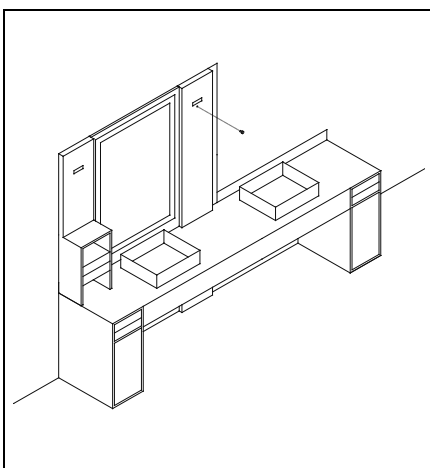

<ul style="list-style-type: none"> • INCASTRARE LA COLONNETTA ALLO SPECCHIO E FISSARLA AL MURO • ENCASTRER LA COLONNE AU MIROIR ET LA FIXER AU MUR • FIX THE COLUMN TO THE MIRROR AND FIX IT TO THE WALL • FIJAR LA COLUMNA AL ESPEJO Y FIJARLO A LA PARED 	<ul style="list-style-type: none"> • PROCEDERE COME AL PUNTO 3 • PROCEDER COMME POINT 3 • PROCEED AS IN STEP 3 • PROCEDER COMO EN EL PASO 3 	<ul style="list-style-type: none"> • INCASTRARE LA COLONNETTA ALLO SPECCHIO E FISSARLA AL MURO COME AL PUNTO 2 • ENCASTRER LA COLONNE AU MIROIR ET LA FIXER AU MUR COMME POINT 2 • FIX THE COLUMN TO THE MIRROR AND FIX IT TO THE WALL AS IN STEP 2 • FIJAR LA COLUMNA AL ESPEJO Y FIJARLO A LA PARED COMO EN EL PASO 2
--	---	---

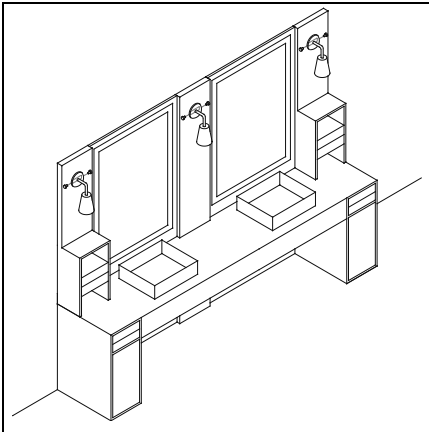

- FISSARE LE LAMPADE DECORATIVE ALLE SQUADRETTE STRINGENDO LE 2 VITI POSTE AI LATI DELL'ATTACCO DI OGNI LAMPADA
- FIXER LES LAMPES AUX SUPPORTS EN SERRANT LES 2 VIS PLACEES AUX COTES DE CHAQUE LAMPE
- FIX THE DECORATIVE LAMPS TO THE BRACKETS BY TIGHTENING THE 2 SCREWS ON THE SIDE OF THE ATTACHMENT OF EACH LAMP
- FIJE LAS LÁMPARAS DECORATIVAS A LOS SOPORTES APRIETE LOS 2 TORNILLOS DEL LADO DE LA UNIDAD DE CADA LÁMPARA

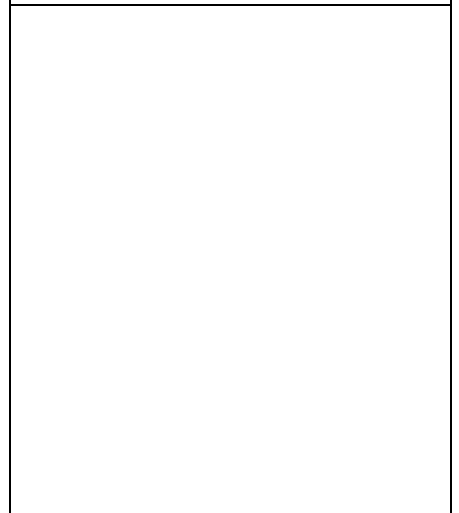
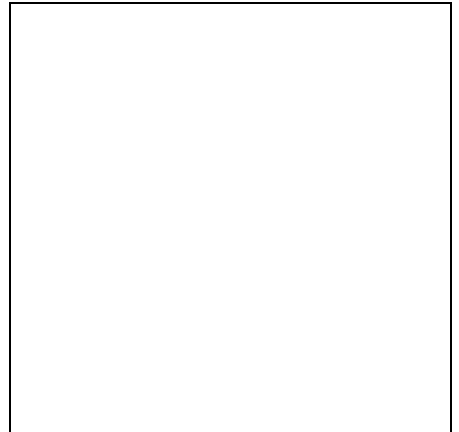
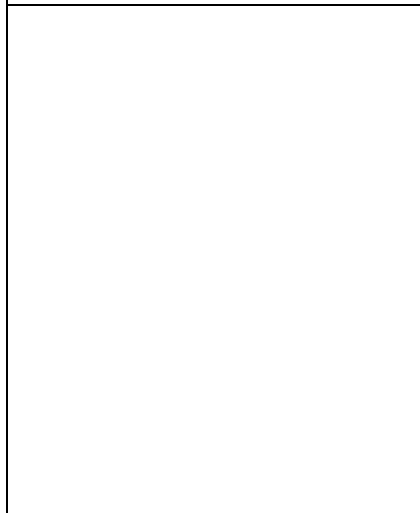
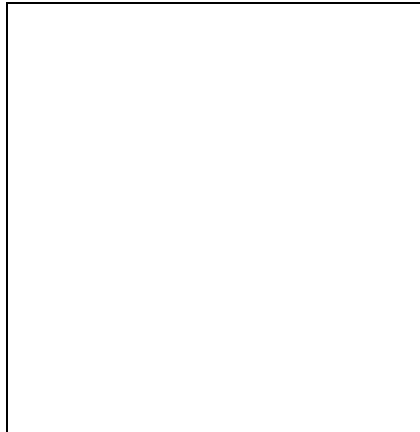

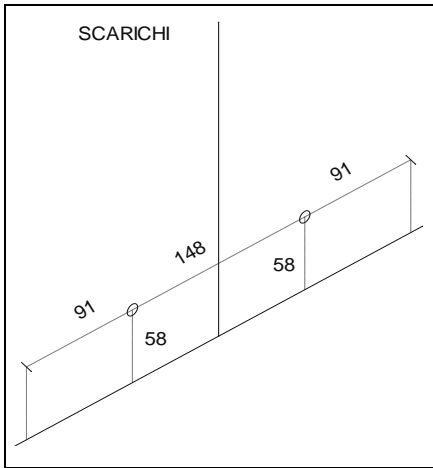
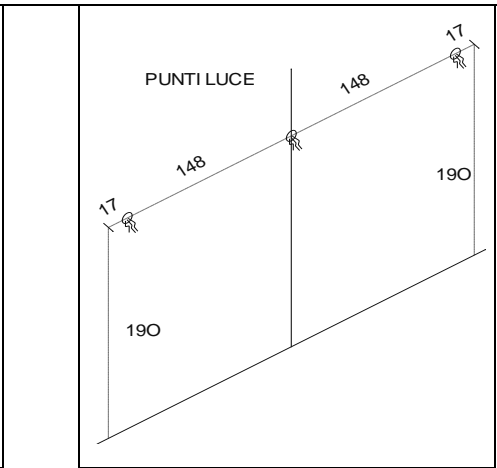
 <p>SCARICHI</p>	 <p>PUNTI LUCE</p>	
<p>CARATTERISTICHE TECNICHE: ALTEZZA SCARICHI 58 CM DA TERRA DISTANZA TRA GLI SCARICHI 148 CM</p> <p>INFOS TECHNIQUES: HAUTEUR ECOULEMENTS 58 CM DU SOL DISTANCE ENTRE ECOULEMENTS 148 CM</p> <p>TECHNICAL FEATURES: HEIGHT OF DRAINS 58 CM FROM THE GROUND DISTANCE BETWEEN THE EXHAUSTS 148 CM</p> <p>CARACTERÍSTICAS TÉCNICAS: ALTURA DESAGÜES A 58 CM DEL SUELO DISTANCIA ENTRE LOS ESCAPES 148 CM</p>	<p>CARATTERISTICHE TECNICHE: ALTEZZA PUNTI LUCE 190 CM DA TERRA DISTANZA TRA I PUNTI LUCE 148 CM</p> <p>INFOS TECHNIQUES: HAUTEUR POINTS LUMIERE 190 CM DU SOL DISTANCE ENTRE POINTS LUMIERE 148 CM</p> <p>TECHNICAL FEATURES: HEIGHT OF LIGHT POINTS 190 CM FROM THE GROUND DISTANCE BETWEEN LIGHT POINTS 148 CM</p> <p>CARACTERÍSTICAS TÉCNICAS: ALTURA DE LOS PUNTOS DE LUZ A 190 CM DEL SUELO DISTANCIA ENTRE PUNTOS DE LUZ 148 CM</p>	